

TSorter

Thickness and Width Measurement System

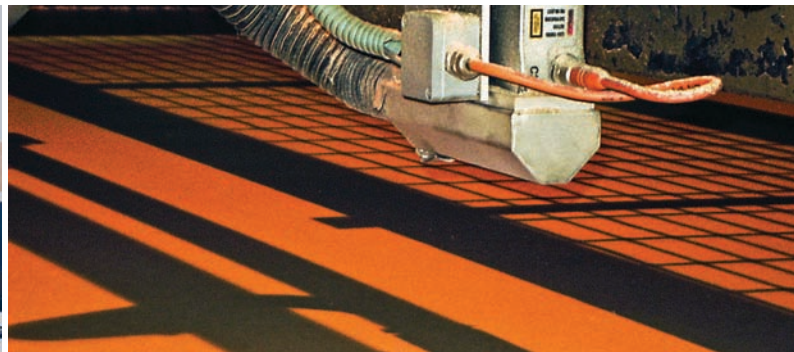

- *Green sorting and other thickness /width measurement applications*
- *Non contact measurement which provides safe and accurate sortin*
- *Various measurement ranges*
- *A variety of interfaces*
- *More than 25 years experience in laser guide lights*



Technical Details

TSorter measures the product thickness by using two PreciCura laser sensors. The sensors can be any model from the PreciCura range whether SR, MR or LR. The width as well as thickness will also be measured by connecting an optional encoder.

Measurements are displayed and are used for sorting, verification and product size documentation.

The system is equipped with a display and keyboard for displaying the measured values and performing calibration.

Applications

The TSorter measures thickness and width of boards, planks and different types of panels on transversal and linear conveyors. Sawmills: green sorting, sorting. Planer mills. Wood based panel production lines: MDF, HDF, Particleboard, Chipboard, OSB, Veneer, Plywood, Hardboard/Glulam. Insulation material lines: Stonewool

(Rockwool), Glasswool, XPS-Extruded Polystyrene. Other types of panel productions: Lightweight/Honeycomb/BOF, Flooring (parquet and plastic) Mixed materials: Fibrecement, wood/plastic/gypsum, "Sandwiches" HPL, Door skins, Metal/cardboard on insulated panels.

LIMAB TSorter

TSorter is a in-process non contact thickness and width measurement system. It is a complete stand-alone measurement system and can be easily integrated with different types of control systems. It is compatible with many older mechanical thickness measurement systems and also LIMAB's earlier TMS 200 and LMS 6203 models.

TSorter uses two LIMAB PreciCura SR/MR/LR laser sensors.

Width can also be measured by connecting an optional encoder.

The system automatically detects the start and end of the object and has a sophisticated statistical filter to ignore splinters and other surface irregularities to improve measurement accuracy.

A clear user display is provided that shows the last thickness and width values measured.

A simple menu system allows the user to calibrate and make configuration changes.

Status messages are displayed simplifying trouble shooting, for example warning of a dirty sensor optic.

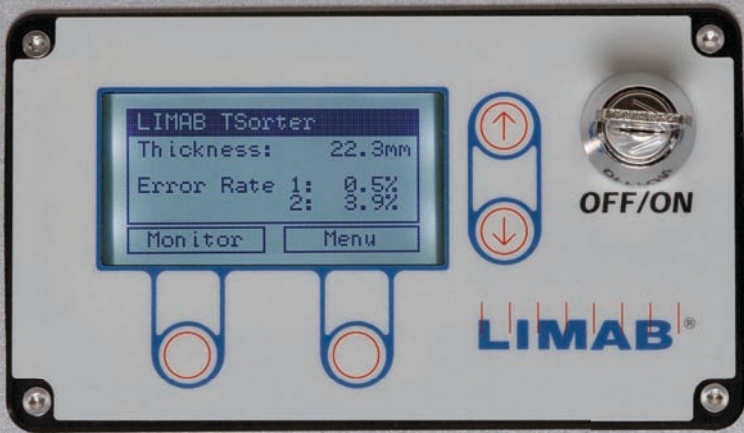

Accessories

C-Frame made from invar and annealed steel which ensures stable accurate measurement.

Air filter kit including solenoid operated valve to keep lower sensor clean from dust.

Encoder for width measurement

Big Display

LIMAB

LIMAB has since its foundation in 1979 supplied various industries with state of the art non-contact measurement sensors and systems. Today the company incorporates production, development, service and sales departments.

During the last few years LIMAB has made large investments in

machinery and personnel to be able to meet the high demands of our customers.

This is a part of our ongoing commitment to provide the market with innovative non-contact measurement solutions.



Technical specifications

TSorter

Measurement range	200 - 8000 mm (7,87 - 315")
Stand off	100 - 2000 mm (3,94 - 78,7")
Accuracy, thickness	+/- 0,1 mm at 200 mm (conveyor dependent) (0,004")
Power supply	18..36 VDC, galvanically isolated
Serial Interface, RS 232C	1200 - 112 500 bit/s ASCII/Comp. ASCII/HEX
Parallel Interface	Binary, BCD, 14bit optical isolated NPN/PNP
Encoder input	Incremental, Grey code, A, b 1000-65000 ppr
Dimensions TSorter box	200 x 400 x 120 mm (hwxwd)

Dimension sensors

PreciCura SR	162 x 108 x 42 mm (6,28 x 4,25 x 1,65")
PreciCura MR	331 x 148 x 56 mm (13,03 x 5,83 x 2,2")
PreciCura LR	551 x 148 x 56 mm (21,69 x 5,83 x 2,2")
Protection class	IP 65, NEMA 4
Connector	PG, terminal block
Operating temperature	0...+40 C (32 - 104 F)

Standard delivery:

- 2 pcs. PreciCura
- 2 pcs. 3 point mounting bracket
- 1 pcs. TSorter controller box
- 2 pcs. Cable sensors - controller (2m)
- 1 pcs. Manual
- 1 pcs. Cable PC - Controller (10m)
- 1 pcs. Air knife lower sensor

LIMAB TSorter is compatible with most other older thickness measurement systems on the market.

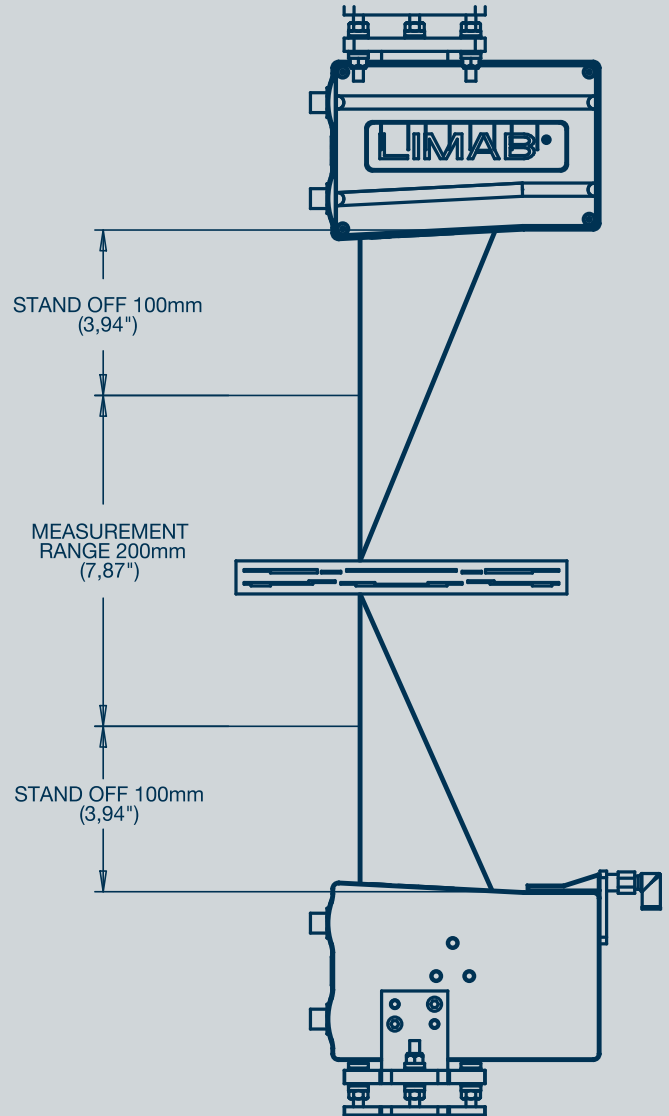
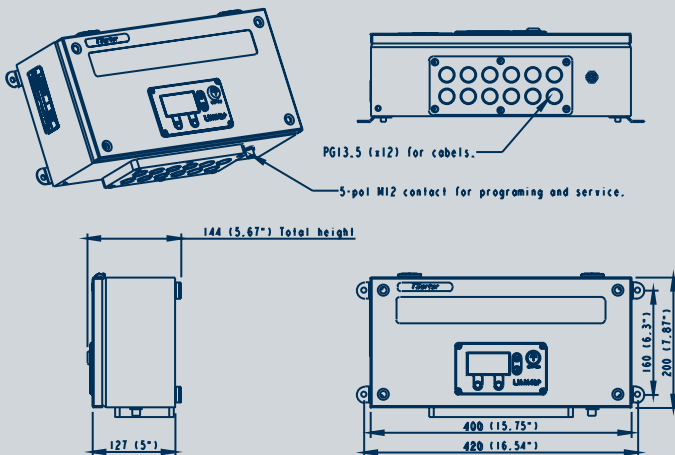

We reserve the right to introduce modifications without prior notice.



Exportgatan 38 B
 SE-422 46 HISINGS BACKA, Sweden
 Phone +46 (0)31 - 58 44 00
 Fax +46 (0)31 - 58 33 88
 sales@limab.se - www.limab.com