

# PanelProfiler

## Board Thickness Measurement System

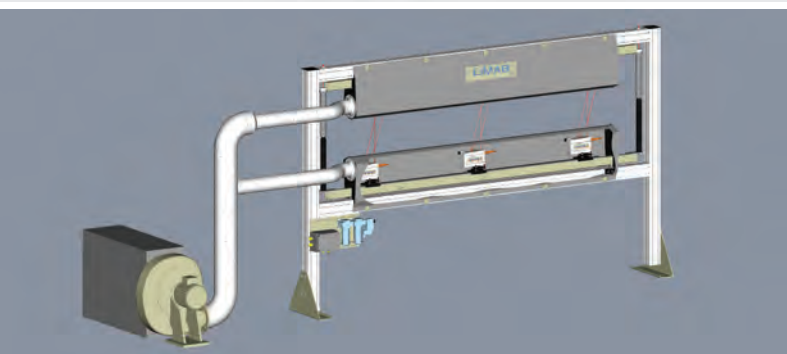

- *High accuracy at all speeds*
- *Non-contact – low maintenance*
- *No marking of surface*
- *Measures thin and soft panels*
- *Increased yield - quick pay back*

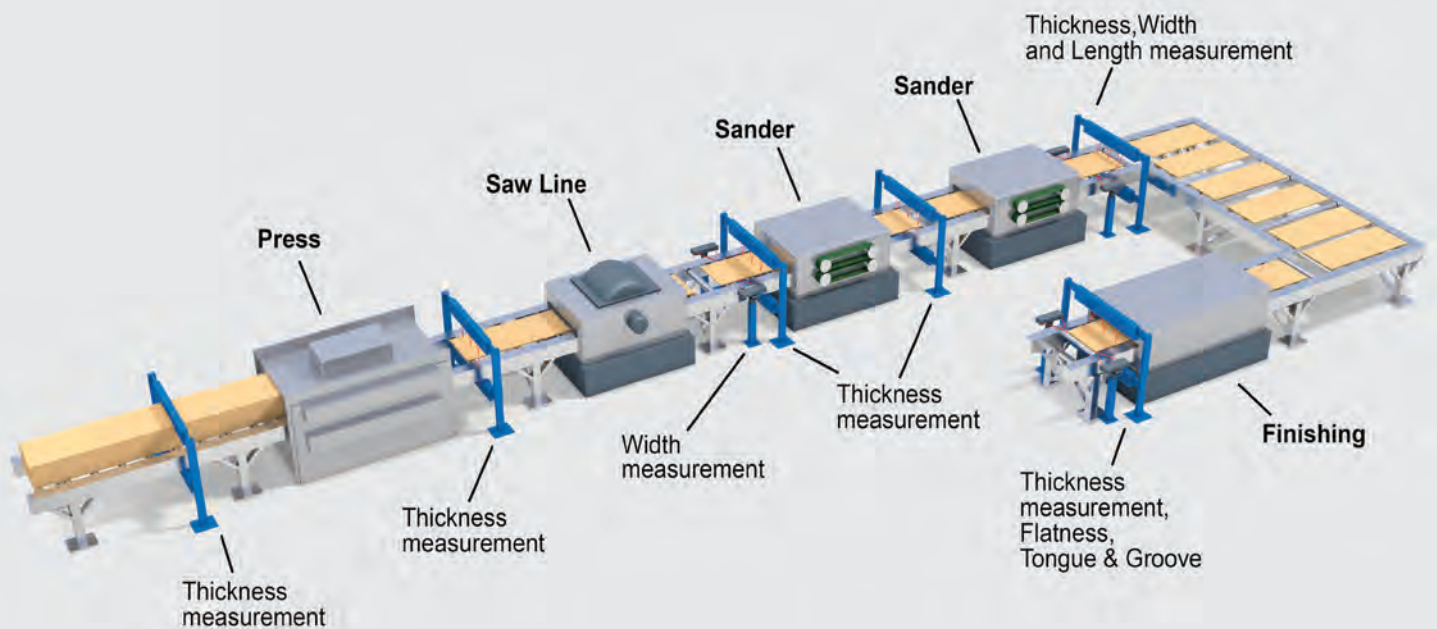

### Designed for harsh conditions

LIMAB has a long experience in supplying laser measuring systems in rough production environments to ensure high accuracy and low maintenance. The PanelProfiler is equipped with a high performance air cleaning system that ensures the sensors are kept clean and cool in warm and humid applications, like after presses. The measuring frame is supplied to meet customer requirements for perfect integration into any process line.

### Designed for accuracy

Achieving high accuracy is not only a question about using precision laser sensors, mechanical design considerations are equally important. The sensor mounting frames are built to minimize thermal distortion by carefully selecting materials with a low coefficient of expansion in combination with stress relieving of critical components by means of annealing. Together this results in a stable measuring system that does not need frequent recalibration. On most lines the product being measured will vibrate, knowing this we have designed a system where this does not affect the measuring accuracy. This is achieved by using a method of differential thickness measurement and high speed synchronized sampling of the sensors at a rate of 4000Hz.

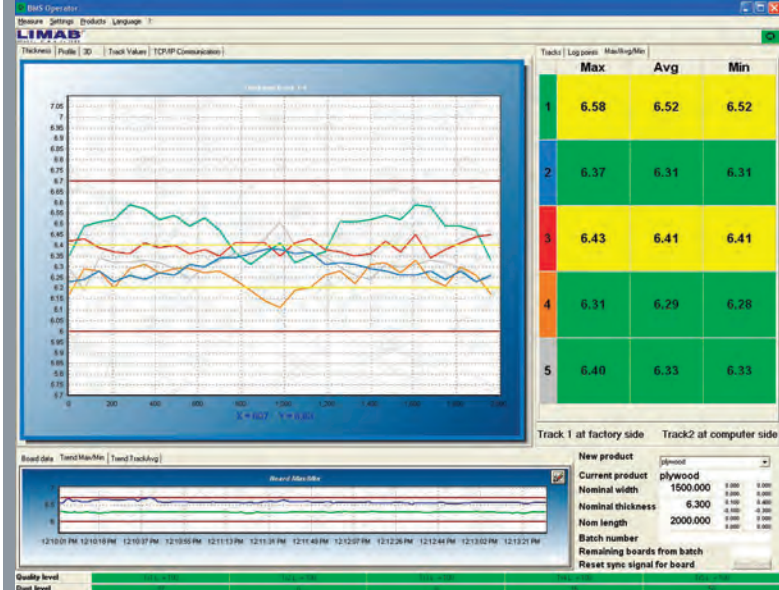

Operator display from a five track system showing thickness graphs, Max, Avg, Min values along with trend charts.

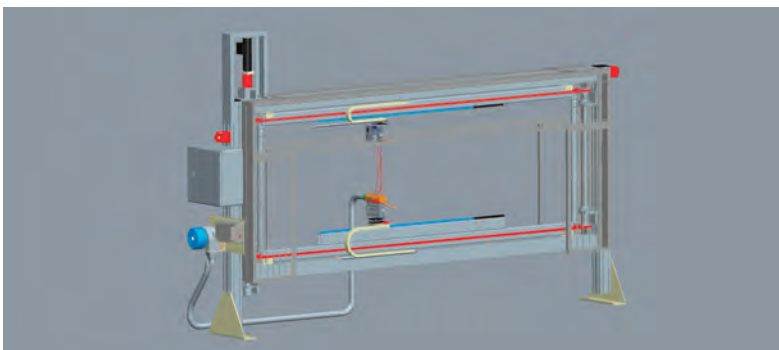
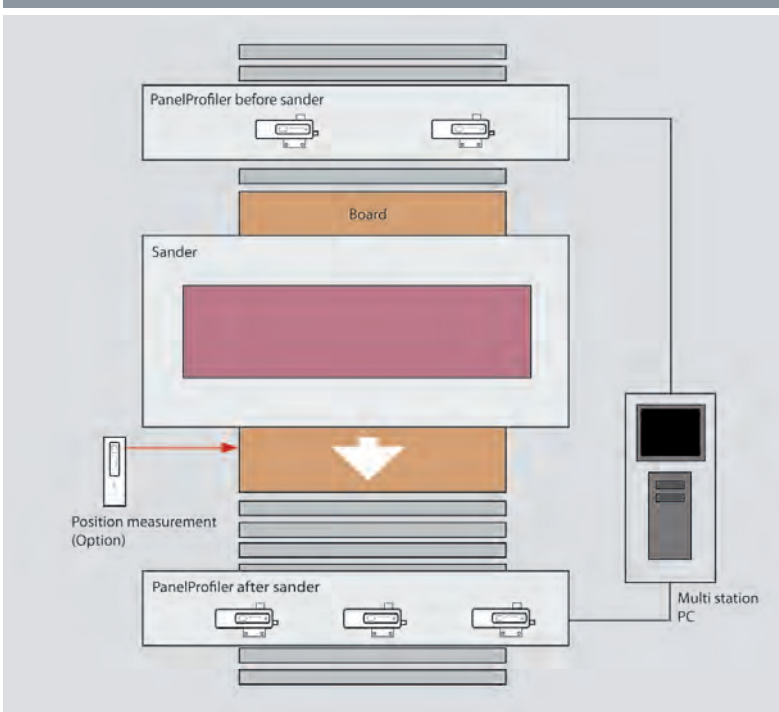

## PanelProfiler – Versions for all applications

**Multi-Track** – User defined number of fixed measurement tracks (3-24). Allows measurement of smallest thickness variations and blows.

**Dual/Triple** – Multiple measurement stations before/between/after sander(s) in one system.

**Width adjustable** – Automatically adjust outer sensors pairs to panel edges.

**Traversing** – Constantly scans giving complete panel cross section profile.

**Single track** – System for measuring at a single position on the panel.

## PanelProfiler

High accuracy – low maintenance costs

PanelProfiler is an in-process non-contact thickness profile measurement system. Having good control of panel thickness is essential during the manufacturing process. The PanelProfiler provides all the tools necessary to ensure that this can be achieved with minimum effort. The system will alert operators immediately if the process is starting to drift out of control improving product quality and eliminating customer rejects. This powerful process monitoring system will also increase the production yield and save both material and energy.

The PanelProfiler uses the latest laser technology to measure using a non contact method. Providing very fast sampling rate of 4000 Hz and high resolution of 0.01mm (0.4 thou). This method has been proved to be more reliable and less costly to maintain than older technologies based on contact measuring rollers. In addition there is the benefit of no product marking or compression. The laser sensors are installed in our unique and temperature stable mounting frame that requires little maintenance. The sensors only need to be cleaned periodically. Being non-contact there is no need for frequent calibration even on high speed and continuous lines. The laser technique ensures no blind spots with the full panel measurement edge to edge.

The easy to use Windows based system software has an extensive set of functions. Real time panel thickness and flatness graphs in 2D and 3D for every panel, on screen alarm indications, trends, product library and user database. In addition production statistics including Cp/Cpk are compiled and are displayed or printed on request.

The system has over the years proved its capacity in many types of panel production facilities including numerous presses, both single and multi-opening types, after sanders and in other finishing lines.



## Applications

PanelProfiler is a high accuracy in-process non contact thickness measuring system. Providing high accuracy on soft or hard materials whether thin or thick.

Typical installations at:

Particleboard  
MDF  
OSB  
Plywood  
Veneer

Hardboard  
Lightweight panels  
Fibreboard  
Laminates  
Rigid foam insulation

# Technical specifications

## PanelProfiler

Measurement range (Other ranges on request)	0,1-200mm ( 0,004-7,9")
Accuracy	±0,03mm ( ±1 thou) ±2σ
Resolution	0,01mm (0,4 thou)
Sampling rate	4000Hz
Operating temperature (Increased temperature range possible)	0-40°C (32-104 °F)
Laser sensor, PreciCura SR: (Larger sensors, PreciCura MR, on request)	
Power	<1mW
Wavelength	670nm
Laser class*	3R
Protection class	IP65, NEMA 4X
PC	
Type	Industrial PC, desktop grade LIMAB configuration 3 network connections
Digital I/O module	XION 4 channels, expandable
Encoder	Rotary absolute
PC Console	
Type	Built-in 17" LCD monitor and key board
Size	600x500x1070mm (24"x20"x42")
Protection class	IP 54
Sensor mounting frame	
Size (Customer specific)	
Height	No limit with leg extensions
Width	≤4000mm (157") without loss of accuracy
Length	<300mm (12")
Installation	Floor mounted



\*Laser Class according to EN 60825-1:2014 and 21 CFR 1040.10 and 1040.11 except for deviations pursuant to Laser Notice No. 50, dated June 24, 2007



We reserve the right to introduce modifications without prior notice.



LIMAB has since its formation in 1979 been dedicated to on-line dimensional measurement in various types of industries. Today we are the market leader in non-contact thickness measurement of wood based panels with more than 100 systems installed worldwide. Design, production and assembly of both laser sensors and complete systems are made in house, backed up by an international service and sales organisation.



LIMAB North America Inc.  
9301 Monroe Road, Suite B  
Charlotte, NC 28270  
USA  
Tel: +1 704 321 0760  
www.limab.com

LIMAB GmbH  
Dompfaffstr. 26  
D-82223 Eichenau  
Germany  
Tel: +49 (0) 89 81415276880  
www.limab.de

LIMAB UK Ltd  
Unit 3L Westpark 26  
Wellington  
Somerset, TA21 9AD UK  
Tel: +44 (0)1823 668633  
www.limab.co.uk



Almedalsvägen 15  
SE-412 63 Gothenburg  
Sweden  
Phone +46 (0)31 - 58 44 00  
sales@limab.se - www.limab.com